

---

# DLMS/COSEM - The infrastructure of liberalisation

Győző Kmethy - DLMS User Association

# Contents

---

- Metering - the impact of market liberalisation
- An independent evaluation of IEC 62056 - DLMS/COSEM
- Latest developments
- Case studies
  - Germany – Gas industry
  - India
  - Korea
  - DLMS based projects: Italy, Hungary
- Summary

# The impact of market liberalisation

- Monopolies
- Stable environment
  - vertical integration
  - long term relationships
- Monthly billing

- Unbundling - competition in all activities
- Fragmented operational environment
  - many stakeholders
  - limited scopes
  - dynamic relationships
- Daily data consolidation

**Metering systems must be based on open standards**

# What to look for – Evaluation criteria\*

- Level of standardization
- Level of openness
- Level of adoption
- Levels of Users' Group Support
- Security
- Manageability
- Scalability
- Use of object modeling
- Use of self-description and meta-data
- Applicability to the Power Industry
- Applicability to the Consumer Domain

\*Source: EPRI „Intelligrid Consumer Portal project”, Evaluation of *Consumer applications technologies*

# The Intelligrid Consumer Portal concept

Consumer Portal: Communications gateway between energy providers and consumers

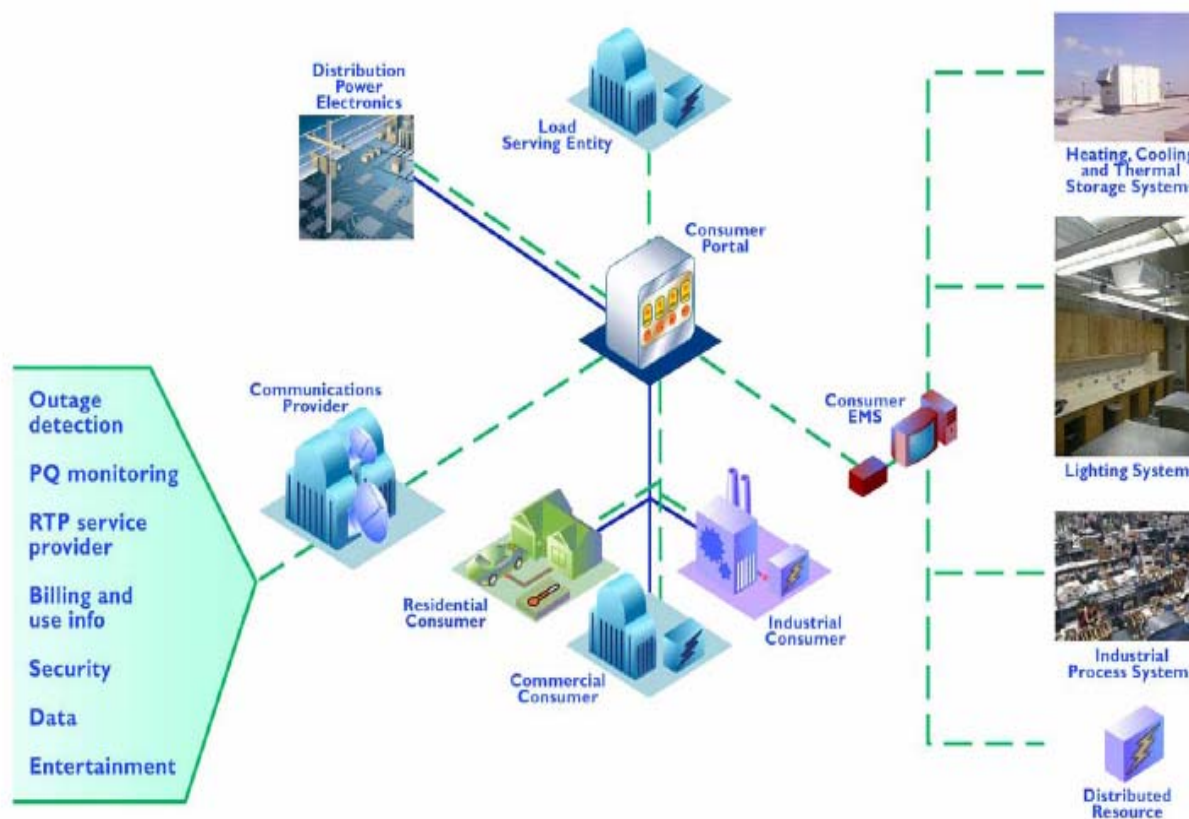

Source: EPRI – Intelligrid project documents

# How IEC 62056 DLMS/COSEM qualifies / 1

- Level of standardization
- Level of openness
- Level of adoption
- Levels of Users' Group Support
- Security
- Manageability

- ✓ Intl'l standard IEC – EN = 5
- ✓ Many vendors = 4
- ✓ Well-known (most users know, but many have not decided) = 3
- ✓ Provides testing = 5
- ✓ Secure as-is (has built in security features) = 4  
(EPRI: Secure if used correctly (= 3))
- ✓ Commonly managed = 4  
(EPRI: No management = 1)

# How DLMS/COSEM qualifies / 2

- Scalability
- Use of object modeling
- Use of self-description and meta-data
- Applicability to the Power Industry
- Applicability to the Consumer Domain

- ✓ Technology can be applied to millions of devices = 4
- ✓ Adresseable (access to „leaf“ portions of the structured data) = 4
- ✓ Negotiation (end points may negotiate important features) = 3
- ✓ Power industry standard (designed for and recognised as) = 5
- ✓ Consumer domain standard (designed for and recognised as) = 5

# How DLMS/COSEM qualifies - summary

---

- **DLMS / COSEM = 76% - #1!**
- Other technologies evaluated:
  - ANSI C12.19 and C12.22 (US- Metering)
  - BACNet (US - Building automation)
  - LONWorks (Building and industrial automation)
  - Konnex (EU - Home and buliding automation)

# Main developments in the last year

- 88 members from 35 countries
- 20 new members, main growth from Asia and Central-East Europe

- IEC 62056 Ed. 2.0 – Q4 2006
  - TCP/IP based profile
  - new interface classes
  - new OBIS identifiers

- First TCP/IP implementations



# DLMS compliant meters

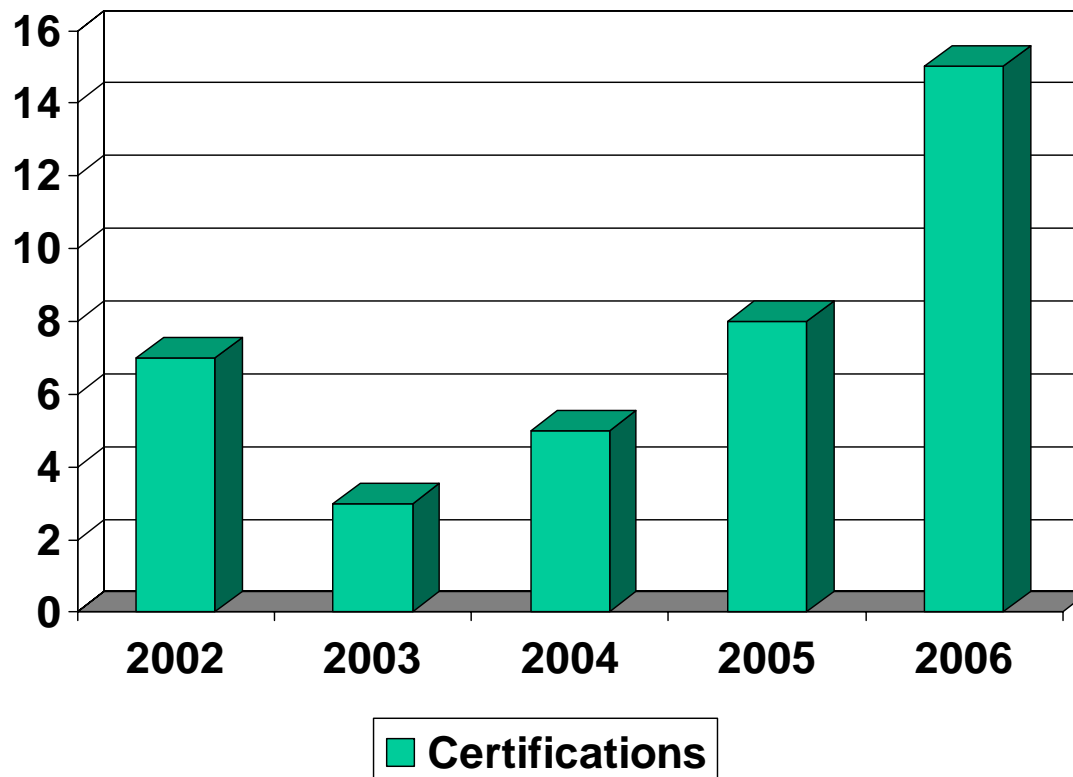

# DLMS/COSEM data collection systems

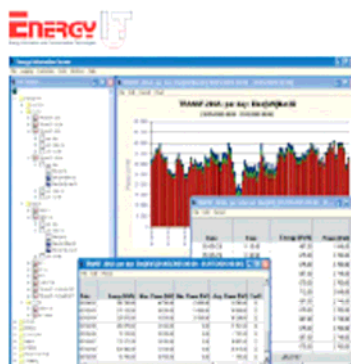

- Fast growing number of client systems:
  - Global and local players
- Smooth system integration
- Tools available

# DLMS/COSEM for the gas industry



Association of the German Gas and Water Industry

- Associated member of the DLMS UA since June 2006
- Reasons:
  - Ongoing liberalisation process in the Gas industry
  - growing number of static metering devices
- Objectives:
  - use international standards for data exchange
  - develop applications to meet new market requirements
- Main activities:
  - new OBIS codes for gas quality measurement
  - application of OBIS codes in data exchange between companies
  - analysis of protocols for use with various categories of gas metering stations

*With acknowledgement of kind contribution of Mr. Jens Brenner - DVGW*

# DLMS/COSEM in India / 1

- Third largest electricity network in the world
- Electricity Act 2003 opened up the market
  - private sector participation
  - mandatory metering of all supply
- Losses and fraud is of special concern
  - special revenue-protection features
- More cost elements
  - energy
  - fixed / rental costs
  - wheeling costs

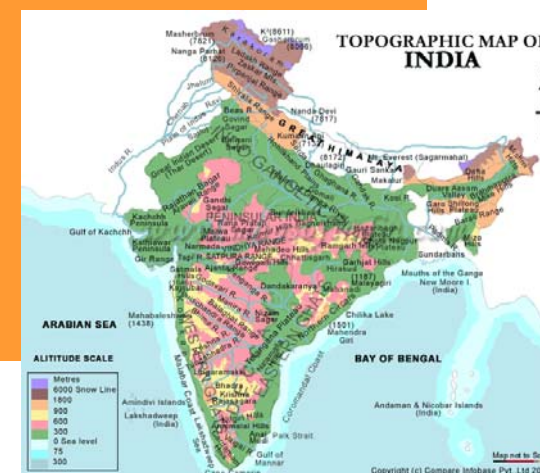

With acknowledgement of kind contribution of Shri N. Murugesan – CPRI

# DLMS/COSEM in India / 2

- Large number of providers
  - proprietary protocols or „standards” not interoperable
- Sourcing meter + system from the same vendor
  - not sustainable in the new environment
- Need for standard
  - object oriented approach and identification system
  - common communication and security profiles
  - interoperability: decrease dependance on vendors
- Large installed park - Migration to be solved
  - Step 1: local initiative – meteringindia.com platform
  - Step 2: all new meters to be IEC 62056 compliant

# DLMS/COSEM in India / 3



- December 2004: CPRI / Bangalore seminar - 150 participants
- Local competencies built
- Promotion
  - to authorities: CBIP, BIS
  - electricity boards,
  - manufacturers
- Many tenders specify IEC 62056 compliant meters
- Many developers are working on meters

# DLMS/COSEM in Korea / 1

- KEPCO, the utility of Korea decided to move to AMR:
  - Residential commercial and industrial
- 21 M e-mechanical meters to be replaced in the next 10 years
- IEC 62056 DLMS/COSEM has been selected



# DLMS/COSEM in Korea / 2



- 11 members, 9 new – utilities, reserch institutes, meter and system providers
- Local conformance testing facilities
- 14 meter types certified

# DLMS/COSEM based projects - Italy

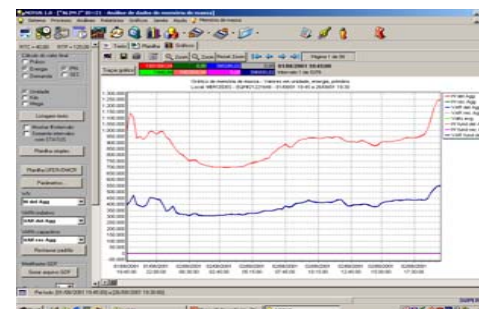

project for 11 000 industrial cabinets to be delivered in 3 months

- Focus on communication speed
- Smooth integration with third party provider's system - Goerlitz
- FAT confirmed communication benchmarks surpassing requirements



Courtesy: Actaris

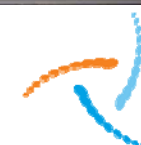

# DLMS/COSEM based projects - Hungary

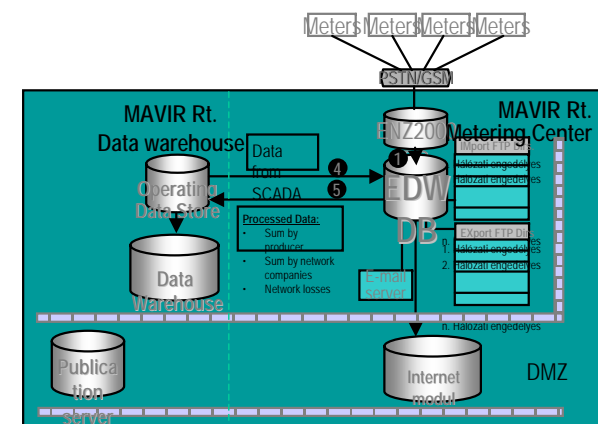
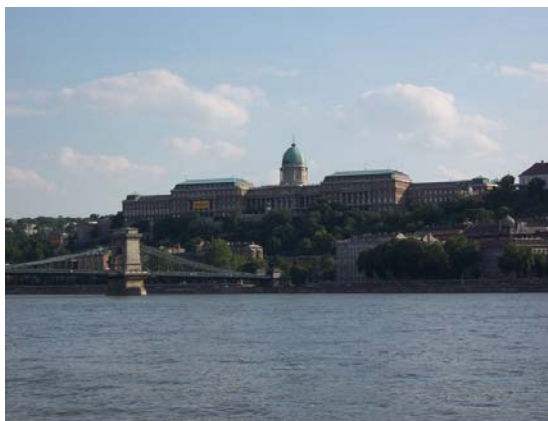

- 2001: Market liberalisation in the C& I segment
- Two markets: competitive and public
- Metering centres operated by MAVIR (TSO) and network licensees to supply market participants with data (warehousing) – 2 system vendors
- OBIS codes used throughout the system, beyond data collector centers
- DLMS/COSEM compliant meters from multiple vendors at:
  - all cross border exchanges
  - all energy interchange points between MAVIR and network operators – some 160 meters
  - eligible customers - some 10,000 meters installed, 3,000 remotely read

# DLMS/COSEM projects - Thailand

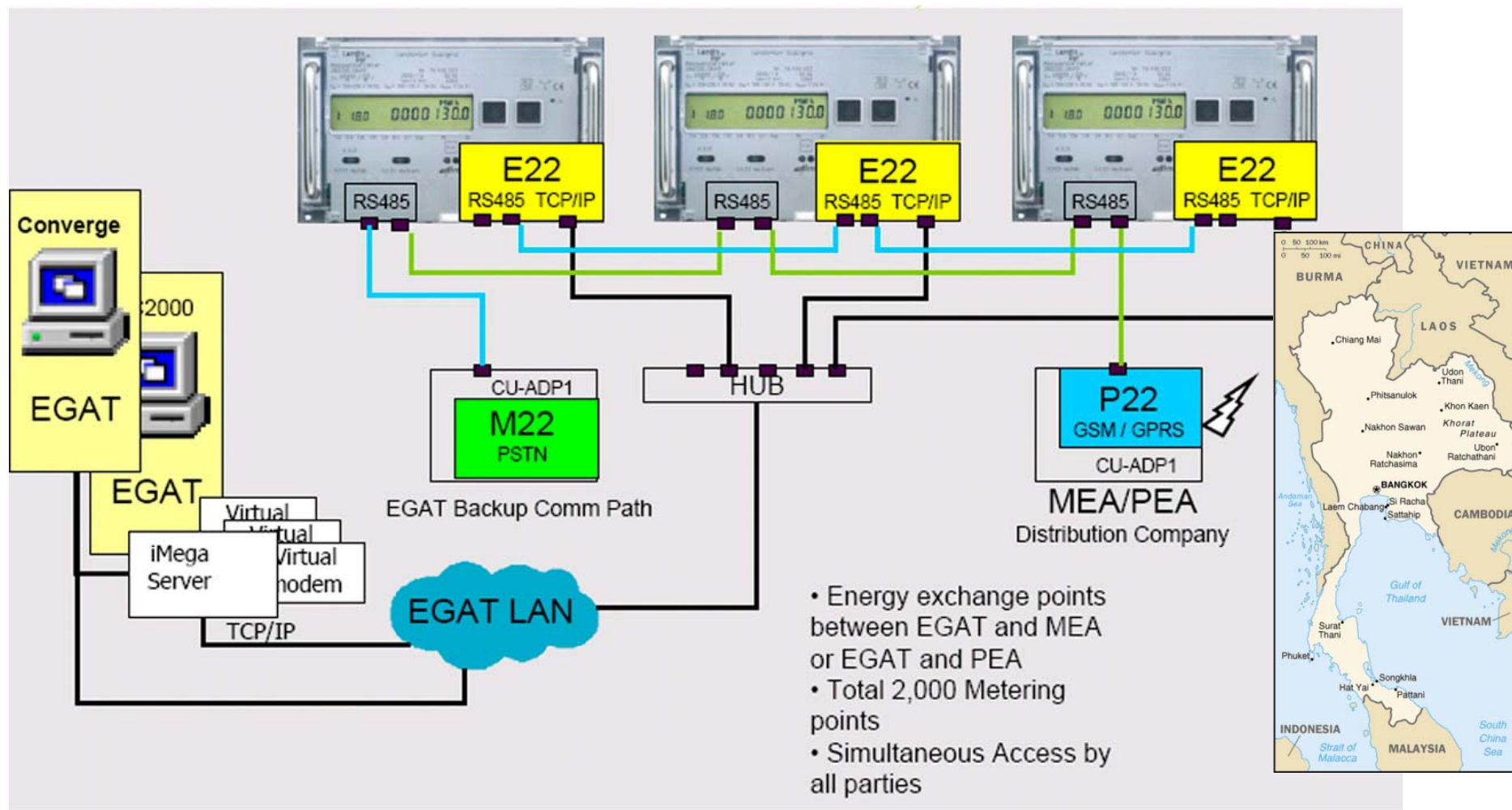

# Summary

- ✓ New market conditions require and new technologies enable smart metering
- ✓ IEC 62056 - DLMS/COSEM meets requirements
- ✓ its use is fast spreading in the world
- ✓ successful projects confirm expectations
- ✓ DLMS/COSEM helps to provide the infrastructure on which the market can move

---

Thank you for your attention!